

# Stresses around an Eccentric Hole in an Infinite Strip Subjected to Side Pressure\*

Tadashi HORIBE\*\* and Eiichiro TSUCHIDA\*\*\*

In this paper, an analytical solution for an infinite strip having an eccentrically located circular hole is given when the strip is subjected to a pair of side pressures. The solution is based on an approach involving Papcovich-Neuber displacement potentials and deduced using the simple forms of Cartesian and cylindrical harmonics. The boundary conditions on both sides of the strip and around the hole are completely satisfied with the aid of the relations between the Cartesian and cylindrical harmonics. The solution is shown in a graph, and the effect of the eccentric hole on the stress distribution is clarified.

**Key Words:** Stress, Strip, Elasticity, Eccentric Hole, Pressure, Stress Concentration, Numerical Analysis

## 1. Introduction

The presence of a defect in a material leads to a stress concentration that may cause either plastic deformation or cracking. Therefore, it is very important to know stresses in engineering design. Stress concentration problems have been addressed by many researchers<sup>(1)-(6)</sup>. The stress concentration factor tends to increase when an elastic body has an unsymmetrically or eccentrically located defect. Thus, the stress concentration caused by an eccentric defect must also be clarified to retain a sufficient strength. Few research studies<sup>(3),(7)-(11)</sup> have been performed for these problems since eccentricity makes an analysis more complex. Such an unsymmetric problem is practically important, and further analysis is expected in engineering design.

In this paper, a solution for an elastic strip having an eccentrically located circular hole is given when the strip is subjected to a pair of side pressures. An analytical method is developed on the basis of a harmonic displacement potential approach. The solution is deduced using the simple forms of Cartesian and cylindrical harmonics in an infinite series and an infinite integral form. The boundary conditions for the strip are satisfied using the relations

between the Cartesian and cylindrical harmonics. Several numerical examples are given to show the stress concentration due to the eccentrically located circular hole.

## 2. Method of Solution

Consider the infinite elastic strip having an eccentrically located hole shown in Fig. 1. Let the origin of coordinates be at the center of the hole and the  $x$ -axis be normal to the edge of the strip. Figure 1 shows the Cartesian coordinates  $(x, y)$  and cylindrical coordinates  $(r, \theta)$ . The half-width of the strip is considered as a unit length. Therefore, without any loss in generality,  $x, y$  and  $r$  are regarded as dimensionless quantities by referring to a typical width of the strip, and we denote the radius of the hole by  $r = a$ , both sides of the strip by  $x = 1 - b$  and  $x = -1 - b$ , where  $b$  is eccentricity. The uniform pressure  $p_0$  acting in the region  $2c$  in length is applied to both sides of the strip as shown in Fig. 1.

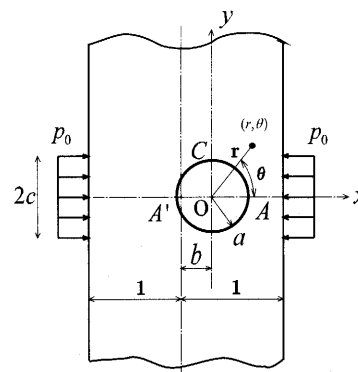

Fig. 1 Coordinate system

\* Received 10th April, 2006 (No. 06-4071)

\*\* Department of Mechanical Engineering, Ibaraki University, 4-12-1 Nakanarusawa-cho, Hitachi-shi, Ibaraki 316-8511, Japan. E-mail: horibe@mx.ibaraki.ac.jp

\*\*\* Department of Mechanical Engineering, Saitama University, 255 Shimoookubo, Sakura-ku, Saitama-shi, Saitama 338-8570, Japan

The governing differential equations, representing equilibrium equations in terms of displacements  $(u, v)$ , are

$$\nabla^2 u + \frac{2}{\kappa - 1} \frac{\partial}{\partial x} \left( \frac{\partial u}{\partial x} + \frac{\partial v}{\partial y} \right) = 0, \tag{1}$$

$$\nabla^2 v + \frac{2}{\kappa - 1} \frac{\partial}{\partial y} \left( \frac{\partial u}{\partial x} + \frac{\partial v}{\partial y} \right) = 0,$$

where  $\nabla^2 = \partial^2/\partial x^2 + \partial^2/\partial y^2$  is Laplacian and  $\kappa = 3 - 4\nu$  (for plane strain) or  $\kappa = (3 - \nu)/(1 + \nu)$  (for plane stress), where  $\nu$  is Poisson's ratio.

Following Papcovich and Neuber, the displacements can be expressed in terms of the harmonic displacement potentials  $\varphi_0$  and  $\varphi_1$  as<sup>(12), (13)</sup>

$$2Gu = \frac{\partial}{\partial x} (\varphi_0 + x\varphi_1) - (\kappa + 1)\varphi_1, \tag{2}$$

$$2Gv = \frac{\partial}{\partial y} (\varphi_0 + x\varphi_1), \tag{3}$$

where  $G$  is the shear modulus,  $\nabla^2 \varphi_0 = 0$  and  $\nabla^2 \varphi_1 = 0$ . Equations (2) and (3) can be expressed in the following cylindrical coordinates:

$$\begin{cases} 2Gu_r = \frac{\partial \varphi_0}{\partial r} + r \cos \theta \frac{\partial \varphi_1}{\partial r} - \kappa \cos \theta \cdot \varphi_1, \\ 2Gv_\theta = \frac{1}{r} \frac{\partial \varphi_0}{\partial \theta} + \cos \theta \frac{\partial \varphi_1}{\partial \theta} + \kappa \sin \theta \cdot \varphi_1. \end{cases} \tag{4}$$

The boundary conditions of the present problem are as follows:

(i) Normal stress must be equal to the external pressure  $p_0$  or zero, and shear stress must be free on both sides of the strip  $x = 1 - b$  and  $x = -1 - b$ ;

$$\begin{aligned} \left( \frac{\sigma_x}{p_0} \right)_{x=1-b} &= \left( \frac{\sigma_x}{p_0} \right)_{x=-1-b} = \begin{cases} -p_0 & (|y| \leq c) \\ 0 & (|y| > c) \end{cases} \\ &= p_0 \int_0^\infty \left( -\frac{2 \sin \lambda c}{\pi \lambda} \right) \cos \lambda y \, d\lambda, \\ \left( \frac{\tau_{xy}}{p_0} \right)_{x=1-b} &= \left( \frac{\tau_{xy}}{p_0} \right)_{x=-1-b} = 0. \end{aligned} \tag{5}$$

(ii) Normal and shear stresses around the hole  $r = a$  must be free;

$$\begin{aligned} \left( \frac{\sigma_r}{p_0} \right)_{r=a} &= 0, \\ \left( \frac{\tau_{r\theta}}{p_0} \right)_{r=a} &= 0. \end{aligned} \tag{6}$$

(iii) All the displacements and stresses must vanish at infinity.

In deriving the required displacement potentials, we should consider that the elastic body consists of the common region of two simply connected domains, i.e., the domain of a strip and that of an infinite body excluding a hole, and we should use the two groups of potentials, namely, those without singularities in the strip and those with singularities at the center of the hole.

Such potentials are expressed by the following cylindrical harmonics and Cartesian harmonics:

$$[I] \begin{cases} \varphi_0 = p_0 \left( -A_0 \log r + \sum_{m=1}^\infty A_m \frac{\cos m\theta}{r^m} \right), \\ \varphi_1 = p_0 \sum_{m=0}^\infty B_m \frac{\cos(m+1)\theta}{r^{m+1}}, \end{cases} \tag{7}$$

$$[II] \begin{cases} \varphi_0 = p_0 \int_0^\infty \left[ \psi_1(\lambda) \cosh \lambda(x+b) \right. \\ \quad \left. + \psi_2(\lambda) \sinh \lambda(x+b) \right] \cos \lambda y \, d\lambda, \\ \varphi_1 = p_0 \int_0^\infty \lambda \left[ \psi_3(\lambda) \cosh \lambda(x+b) \right. \\ \quad \left. + \psi_4(\lambda) \sinh \lambda(x+b) \right] \cos \lambda y \, d\lambda, \end{cases} \tag{8}$$

where  $A_n$  and  $B_n$  are unknown constants, and  $\psi_1(\lambda)$ ,  $\psi_2(\lambda)$ ,  $\psi_3(\lambda)$  and  $\psi_4(\lambda)$  are unknown functions. It should be noted that potentials [I] account for the disturbance in the strip excluding a hole, while potentials [II] allow for the satisfaction of the boundary conditions on both sides of the strip.

For convenience, we split potentials [I] into

$$[I]1 \left\{ \varphi_0 = -p_0 A_0 \log r, \right. \tag{9}$$

$$[I]2 \begin{cases} \varphi_0 = p_0 \sum_{m=1}^\infty A_m \frac{\cos m\theta}{r^m}, \\ \varphi_1 = p_0 \sum_{m=0}^\infty B_m \frac{\cos(m+1)\theta}{r^{m+1}}. \end{cases} \tag{10}$$

### 2.1 Boundary conditions on both sides of strip

To satisfy the boundary conditions on both sides of the strip, we employ the following transformation formula of harmonic functions:

$$\begin{aligned} \left. \begin{aligned} \frac{\cos m\theta}{r^m} &= \frac{1}{(m-1)!} \int_0^\infty \lambda^{m-1} e^{-\lambda x} \cos \lambda y \, d\lambda \\ \frac{\sin m\theta}{r^m} &= \frac{1}{(m-1)!} \int_0^\infty \lambda^{m-1} e^{-\lambda x} \sin \lambda y \, d\lambda \end{aligned} \right\} (x > 0), \\ \left. \begin{aligned} \frac{\cos m\theta}{r^m} &= \frac{(-1)^m}{(m-1)!} \int_0^\infty \lambda^{m-1} e^{\lambda x} \cos \lambda y \, d\lambda \\ \frac{\sin m\theta}{r^m} &= \frac{(-1)^{m+1}}{(m-1)!} \int_0^\infty \lambda^{m-1} e^{\lambda x} \sin \lambda y \, d\lambda \end{aligned} \right\} (x < 0). \end{aligned} \tag{11}$$

If we rewrite displacement potential [I]2 into the sum of odd and even orders of  $r$ , i.e.,

$$\begin{cases} \varphi_0 = p_0 \sum_{m=1}^\infty A_m \frac{\cos m\theta}{r^m} \\ \quad = p_0 \sum_{m=1}^\infty A_{2m} \frac{\cos 2m\theta}{r^{2m}} + p_0 \sum_{m=0}^\infty A_{2m+1} \frac{\cos(2m+1)\theta}{r^{2m+1}}, \\ \varphi_1 = p_0 \sum_{m=0}^\infty B_m \frac{\cos(m+1)\theta}{r^{m+1}} \\ \quad = p_0 \sum_{m=1}^\infty B_{2m-1} \frac{\cos 2m\theta}{r^{2m}} + p_0 \sum_{m=0}^\infty B_{2m} \frac{\cos(2m+1)\theta}{r^{2m+1}}, \end{cases} \tag{12}$$

we obtain displacement potentials [I] using relations (11) in the following Cartesian coordinates:

$$\begin{cases}
 \text{[III]} \left\{ \begin{aligned}
 \varphi_0 &= p_0 \sum_{m=1}^{\infty} \frac{A_{2m}}{(2m-1)!} \int_0^{\infty} \lambda^{2m-1} e^{-\lambda x} \cos \lambda y \, d\lambda \\
 &+ p_0 \sum_{m=0}^{\infty} \frac{A_{2m+1}}{(2m)!} \int_0^{\infty} \lambda^{2m} e^{-\lambda x} \cos \lambda y \, d\lambda \\
 \varphi_1 &= p_0 \sum_{m=1}^{\infty} \frac{B_{2m-1}}{(2m-1)!} \int_0^{\infty} \lambda^{2m-1} e^{-\lambda x} \cos \lambda y \, d\lambda \\
 &+ p_0 \sum_{m=0}^{\infty} \frac{B_{2m}}{(2m)!} \int_0^{\infty} \lambda^{2m} e^{-\lambda x} \cos \lambda y \, d\lambda
 \end{aligned} \right. \quad (x > 0), \quad (13) \\
 \text{[III]} \left\{ \begin{aligned}
 \varphi_0 &= p_0 \sum_{m=1}^{\infty} \frac{A_{2m}}{(2m-1)!} \int_0^{\infty} \lambda^{2m-1} e^{\lambda x} \cos \lambda y \, d\lambda \\
 &- p_0 \sum_{m=0}^{\infty} \frac{A_{2m+1}}{(2m)!} \int_0^{\infty} \lambda^{2m} e^{\lambda x} \cos \lambda y \, d\lambda \\
 \varphi_1 &= p_0 \sum_{m=1}^{\infty} \frac{B_{2m-1}}{(2m-1)!} \int_0^{\infty} \lambda^{2m-1} e^{\lambda x} \cos \lambda y \, d\lambda \\
 &- p_0 \sum_{m=0}^{\infty} \frac{B_{2m}}{(2m)!} \int_0^{\infty} \lambda^{2m} e^{\lambda x} \cos \lambda y \, d\lambda
 \end{aligned} \right. \quad (x < 0).
 \end{cases}$$

On the other hand, we have no formula expressing displacement potential [I] in the Cartesian form. Now, after calculating stress components using [I] in cylindrical coordinates and then transforming them into the Cartesian form, we can obtain the following stress components in Cartesian coordinates:

$$\left. \begin{aligned}
 \frac{\sigma_x}{p_0} &= A_0 \int_0^{\infty} \lambda e^{-\lambda x} \cos \lambda y \, d\lambda, \quad (x > 0) \\
 \frac{\tau_{xy}}{p_0} &= A_0 \int_0^{\infty} \lambda e^{-\lambda x} \sin \lambda y \, d\lambda, \quad (x > 0) \\
 \frac{\sigma_x}{p_0} &= A_0 \int_0^{\infty} \lambda e^{\lambda x} \cos \lambda y \, d\lambda, \quad (x < 0) \\
 \frac{\tau_{xy}}{p_0} &= -A_0 \int_0^{\infty} \lambda e^{\lambda x} \sin \lambda y \, d\lambda \quad (x < 0)
 \end{aligned} \right\}. \quad (14)$$

To satisfy the boundary conditions on both sides of the strip, we derive stress components from potentials [II] and [III]. Next, adding the stress components expressed by Eq. (14) to them, we obtain

$$\begin{aligned}
 \left( \frac{\sigma_x}{p_0} \right)_{x=1-b} &= \int_0^{\infty} \lambda^2 \left[ \psi_1(\lambda) \cosh \lambda + \psi_2(\lambda) \sinh \lambda \right. \\
 &+ \psi_3(\lambda) \left\{ (1-b)\lambda \cosh \lambda - \frac{\kappa+1}{2} \sinh \lambda \right\} \\
 &+ \psi_4(\lambda) \left\{ -\frac{\kappa+1}{2} \cosh \lambda + (1-b)\lambda \sinh \lambda \right\} + \frac{A_0}{\lambda} e^{-(1-b)\lambda} \\
 &+ \sum_{m=1}^{\infty} \frac{A_{2m}}{(2m-1)!} \lambda^{2m-1} e^{-(1-b)\lambda} + \sum_{m=0}^{\infty} \frac{A_{2m+1}}{(2m)!} \lambda^{2m} e^{-(1-b)\lambda} \\
 &+ \sum_{m=1}^{\infty} \left\{ \frac{\kappa+1}{2} + (1-b)\lambda \right\} \frac{B_{2m-1}}{(2m-1)!} \lambda^{2m-2} e^{-(1-b)\lambda} \\
 &+ \sum_{m=0}^{\infty} \left\{ \frac{\kappa+1}{2} + (1-b)\lambda \right\} \frac{B_{2m}}{(2m)!} \lambda^{2m-1} e^{-(1-b)\lambda} \\
 &\left. + \frac{2 \sin \lambda c}{\pi \lambda^3} \right] \cos \lambda y \, d\lambda = 0, \quad (15)
 \end{aligned}$$

$$\begin{aligned}
 \left( \frac{\tau_{xy}}{p_0} \right)_{x=1-b} &= \int_0^{\infty} \lambda^2 \left[ -\psi_1(\lambda) \sinh \lambda - \psi_2(\lambda) \cosh \lambda \right. \\
 &+ \psi_3(\lambda) \left\{ \frac{\kappa-1}{2} \cosh \lambda + (-1+b)\lambda \sinh \lambda \right\} \\
 &+ \psi_4(\lambda) \left\{ (-1+b)\lambda \cosh \lambda + \frac{\kappa-1}{2} \sinh \lambda \right\} + \frac{A_0}{\lambda} e^{-(1-b)\lambda} \\
 &+ \sum_{m=1}^{\infty} \frac{A_{2m}}{(2m-1)!} \lambda^{2m-1} e^{-(1-b)\lambda} + \sum_{m=0}^{\infty} \frac{A_{2m+1}}{(2m)!} \lambda^{2m} e^{-(1-b)\lambda} \\
 &+ \sum_{m=1}^{\infty} \frac{B_{2m-1}}{(2m-1)!} \left\{ \frac{\kappa-1}{2} + (1-b)\lambda \right\} \lambda^{2m-2} e^{-(1-b)\lambda} \\
 &+ \sum_{m=0}^{\infty} \frac{B_{2m}}{(2m)!} \left\{ \frac{\kappa-1}{2} + (1-b)\lambda \right\} \lambda^{2m-1} e^{-(1-b)\lambda} \left. \right] \\
 &\times \sin \lambda y \, d\lambda = 0, \quad (16)
 \end{aligned}$$

$$\begin{aligned}
 \left( \frac{\sigma_x}{p_0} \right)_{x=-1-b} &= \int_0^{\infty} \lambda^2 \left[ \psi_1(\lambda) \cosh \lambda - \psi_2(\lambda) \sinh \lambda \right. \\
 &+ \psi_3(\lambda) \left\{ -(1+b)\lambda \cosh \lambda + \frac{\kappa+1}{2} \sinh \lambda \right\} \\
 &+ \psi_4(\lambda) \left\{ -\frac{\kappa+1}{2} \cosh \lambda + \frac{1+b}{2} \lambda \sinh \lambda \right\} + \frac{A_0}{\lambda} e^{-(1+b)\lambda} \\
 &+ \sum_{m=1}^{\infty} \frac{A_{2m}}{(2m-1)!} \lambda^{2m-1} e^{-(1+b)\lambda} - \sum_{m=0}^{\infty} \frac{A_{2m+1}}{(2m)!} \lambda^{2m} e^{-(1+b)\lambda} \\
 &- \sum_{m=1}^{\infty} \frac{B_{2m-1}}{(2m-1)!} \left\{ \frac{\kappa+1}{2} + (1+b)\lambda \right\} \lambda^{2m-2} e^{-(1+b)\lambda} \\
 &+ \sum_{m=0}^{\infty} \frac{B_{2m}}{(2m)!} \left\{ \frac{\kappa+1}{2} + (1+b)\lambda \right\} \lambda^{2m-1} e^{-(1+b)\lambda} \\
 &\left. + \frac{2 \sin \lambda c}{\pi \lambda^3} \right] \cos \lambda y \, d\lambda = 0, \quad (17)
 \end{aligned}$$

$$\begin{aligned}
 \left( \frac{\tau_{xy}}{p_0} \right)_{x=-1-b} &= \int_0^{\infty} \lambda^2 \left[ \psi_1(\lambda) \sinh \lambda - \psi_2(\lambda) \cosh \lambda \right. \\
 &+ \psi_3(\lambda) \left\{ \frac{\kappa-1}{2} \cosh \lambda - (1+b)\lambda \sinh \lambda \right\} \\
 &+ \psi_4(\lambda) \left\{ (1+b)\lambda \cosh \lambda - \frac{\kappa-1}{2} \sinh \lambda \right\} - \frac{A_0}{\lambda} e^{-(1+b)\lambda} \\
 &- \sum_{m=1}^{\infty} \frac{A_{2m}}{(2m-1)!} \lambda^{2m-1} e^{-(1+b)\lambda} + \sum_{m=0}^{\infty} \frac{A_{2m+1}}{(2m)!} \lambda^{2m} e^{-(1+b)\lambda} \\
 &+ \sum_{m=1}^{\infty} \frac{B_{2m-1}}{(2m-1)!} \left\{ \frac{\kappa-1}{2} + (1+b)\lambda \right\} \lambda^{2m-2} e^{-(1+b)\lambda} \\
 &- \sum_{m=0}^{\infty} \frac{B_{2m}}{(2m)!} \left\{ \frac{\kappa-1}{2} + (1+b)\lambda \right\} \lambda^{2m-1} e^{-(1+b)\lambda} \left. \right] \\
 &\times \sin \lambda y \, d\lambda = 0. \quad (18)
 \end{aligned}$$

Applying the inverse Fourier transforms to Eqs. (15)–(18), we determine the unknown functions  $\psi_1(\lambda) \sim \psi_4(\lambda)$  to be

$$\psi_1(\lambda) = \left[ -\frac{e^{-(2+b)\lambda} (1 + e^{2b\lambda}) (-1 + (2\lambda - \kappa)e^{2\lambda})}{2\lambda(2\lambda + \sinh 2\lambda)} \right]$$

$$\begin{aligned}
 & - \frac{2b \sinh b\lambda}{2\lambda - \sinh 2\lambda} \Big| A_0 \\
 & + \sum_{m=1}^{\infty} \frac{\lambda^{2m-1}}{2(2m-1)!} e^{-(2+b)\lambda} \left[ - \frac{2b\lambda e^{2\lambda}(-1 + e^{2b\lambda})}{2\lambda - \sinh 2\lambda} \right. \\
 & \quad \left. - \frac{(1 + e^{2b\lambda})(-1 + (2\lambda - \kappa)e^{2\lambda})}{2\lambda + \sinh 2\lambda} \right] A_{2m} \\
 & + \sum_{m=0}^{\infty} \frac{\lambda^{2m} e^{-(1+b)\lambda}}{2(2m)!} \left[ - \frac{2b\lambda e^{\lambda}(1 + e^{2b\lambda})}{2\lambda - \sinh 2\lambda} \right. \\
 & \quad \left. - \frac{(-1 + e^{2b\lambda})(2\lambda - \kappa)e^{\lambda} - e^{-\lambda}}{2\lambda + \sinh 2\lambda} \right] A_{2m+1} \\
 & + \sum_{m=1}^{\infty} \frac{\lambda^{2m-2}}{(2m-1)!(4\lambda^2 - \sinh^2 2\lambda)} \\
 & \times \left[ -4b\lambda^2(\kappa + \cosh 2\lambda) \cosh b\lambda \right. \\
 & \quad \left. + \left\{ \lambda(\kappa^2 - 1 - 4(1 - b^2)\lambda^2) \right. \right. \\
 & \quad \left. \left. + (1 - \kappa^2 + 4(1 + b^2)\lambda^2) \cosh \lambda \sinh \lambda \right\} \sinh b\lambda \right] B_{2m-1} \\
 & + \sum_{m=0}^{\infty} \frac{\lambda^{2m-1}}{(2m)!(4\lambda^2 - \sinh^2 2\lambda)} \left[ \left\{ \lambda(\kappa^2 - 1 - 4(1 - b^2)\lambda^2) \right. \right. \\
 & \quad \left. \left. + (1 - \kappa^2 + 4(1 + b^2)\lambda^2) \cosh \lambda \sinh \lambda \right\} \cosh b\lambda \right. \\
 & \quad \left. - 4b\lambda^2(\kappa + \cosh 2\lambda) \sinh b\lambda \right] B_{2m} \\
 & - \frac{2 \sin \lambda c \{ 2\lambda \cosh \lambda + (1 - \kappa) \sinh \lambda \}}{\pi \lambda^3 (2\lambda + \sinh 2\lambda)}, \tag{19} \\
 \psi_2(\lambda) & = \left[ \frac{2b \cosh b\lambda}{2\lambda + \sinh 2\lambda} + \frac{\sinh b\lambda (e^{-2\lambda} - \kappa + 2\lambda)}{\lambda(2\lambda - \sinh 2\lambda)} \right] A_0 \\
 & + \sum_{m=1}^{\infty} \frac{\lambda^{2m-1}}{2(2m-1)!(4\lambda^2 - \sinh^2 2\lambda)} \\
 & \times \left[ 8b\lambda(\lambda - \cosh \lambda \sinh \lambda) \cosh b\lambda \right. \\
 & \quad \left. - 2e^{-\lambda} \left\{ (\kappa - 1 - 2\lambda) \cosh \lambda + (\kappa + 1 - 2\lambda) \sinh \lambda \right\} \right. \\
 & \quad \left. \times (2\lambda + \sinh 2\lambda) \sinh b\lambda \right] A_{2m} \\
 & - \sum_{m=0}^{\infty} \frac{\lambda^{2m}}{4(2m)!(4\lambda^2 - \sinh^2 2\lambda)} \left[ e^{-(4+b)\lambda} (1 + e^{2b\lambda}) \right. \\
 & \quad \left. - 2(1 - 4\kappa\lambda + 8\lambda^2 + 4\lambda \cosh 2\lambda - 2\kappa \sinh 2\lambda) \cosh b\lambda \right. \\
 & \quad \left. + 8b\lambda(-2\lambda + \sinh 2\lambda) \sinh b\lambda \right] A_{2m+1} \\
 & + \sum_{m=1}^{\infty} \frac{\lambda^{2m-2}}{(2m-1)!(4\lambda^2 - \sinh^2 2\lambda)} \\
 & \times \left[ \left\{ (1 - \kappa^2)\lambda + 4(1 - b^2)\lambda^3 \right\} \right.
 \end{aligned}$$

$$\begin{aligned}
 & \left. + (1 - \kappa^2 + 4(1 + b^2)\lambda^2) \sinh \lambda \cosh \lambda \right\} \cosh b\lambda \\
 & + 4b\lambda^2(\kappa - \cosh 2\lambda) \sinh b\lambda \Big] B_{2m-1} \\
 & + \sum_{m=0}^{\infty} \frac{\lambda^{2m-1}}{(2m)!(4\lambda^2 - \sinh^2 2\lambda)} \\
 & \times \left[ 4b\lambda^2(\kappa - \cosh 2\lambda) \cosh b\lambda \right. \\
 & \quad \left. + \left\{ \lambda(1 - \kappa^2 + 4(1 - b^2)\lambda^2) \right. \right. \\
 & \quad \left. \left. + (1 - \kappa^2 + 4(1 + b^2)\lambda^2) \sinh \lambda \cosh \lambda \right\} \sinh b\lambda \right] B_{2m} \\
 & + \frac{4b \sin \lambda c \sinh \lambda}{\pi \lambda^2 (2\lambda + \sinh 2\lambda)}, \tag{20}
 \end{aligned}$$

$$\begin{aligned}
 \psi_3(\lambda) & = - \frac{2 \sinh b\lambda}{\lambda(2\lambda - \sinh 2\lambda)} A_0 \\
 & - \sum_{m=1}^{\infty} \frac{2\lambda^{2m-1} \sinh b\lambda}{(2m-1)!(2\lambda - \sinh 2\lambda)} A_{2m} \\
 & - \sum_{m=0}^{\infty} \frac{2\lambda^{2m} \cosh b\lambda}{(2m)!(2\lambda - \sinh 2\lambda)} A_{2m+1} \\
 & + \sum_{m=1}^{\infty} \frac{\lambda^{2m-2}}{(2m-1)!(2\lambda - \sinh 2\lambda)} \\
 & \times \left[ - (e^{-2\lambda} + \kappa + 2\lambda) \cosh b\lambda + 2b\lambda \sinh b\lambda \right] B_{2m-1} \\
 & + \sum_{m=0}^{\infty} \frac{\lambda^{2m-1}}{(2m)!(2\lambda - \sinh 2\lambda)} \left[ 2b\lambda \cosh b\lambda \right. \\
 & \quad \left. - (\kappa + 2\lambda + \cosh 2\lambda - \sinh 2\lambda) \sinh b\lambda \right] B_{2m}, \tag{21}
 \end{aligned}$$

$$\begin{aligned}
 \psi_4(\lambda) & = \frac{2 \cosh b\lambda}{\lambda(2\lambda + \sinh 2\lambda)} A_0 \\
 & + \sum_{m=1}^{\infty} \frac{2\lambda^{2m-1} \cosh b\lambda}{(2m-1)!(2\lambda + \sinh 2\lambda)} A_{2m} \\
 & + \sum_{m=0}^{\infty} \frac{2\lambda^{2m} \sinh b\lambda}{(2m)!(2\lambda + \sinh 2\lambda)} A_{2m+1} \\
 & + \sum_{m=1}^{\infty} \frac{\lambda^{2m-2}}{(2m-1)!(2\lambda + \sinh 2\lambda)} \\
 & \times \left[ -2b\lambda \cosh b\lambda + (\kappa + 2\lambda - e^{-2\lambda}) \sinh b\lambda \right] B_{2m-1} \\
 & + \sum_{m=0}^{\infty} \frac{\lambda^{2m-1}}{(2m)!(2\lambda + \sinh 2\lambda)} \\
 & \times \left[ (\kappa + 2\lambda - e^{-2\lambda}) \cosh b\lambda - 2b\lambda \sinh b\lambda \right] B_{2m} \\
 & + \frac{4 \sin \lambda c \sinh \lambda}{\pi \lambda^3 (2\lambda + \sinh 2\lambda)}. \tag{22}
 \end{aligned}$$

Equations (19)–(22) indicate the conditions of zero tractions on both sides of the strip. If these equations are sat-

ified, boundary conditions (5) are satisfied for any values of the unknown constants  $A_m$  and  $B_m$ .

## 2.2 Boundary conditions on rim of hole

To adjust the remaining boundary conditions on the rim of the hole given by Eq. (6), it is necessary to expand potential [III] in cylindrical coordinates. In view of the following relations of harmonics

$$\begin{aligned} & \cosh \lambda(x+b) \cos \lambda y \\ &= \cosh \lambda b \sum_{n=0}^{\infty} \frac{(\lambda r)^{2n}}{(2n)!} \cos 2n\theta \\ &+ \sinh \lambda b \sum_{n=0}^{\infty} \frac{(\lambda r)^{2n+1}}{(2n+1)!} \cos(2n+1)\theta, \\ & \sinh \lambda(x+b) \cos \lambda y \\ &= \cosh \lambda b \sum_{n=0}^{\infty} \frac{(\lambda r)^{2n+1}}{(2n+1)!} \cos(2n+1)\theta \\ &+ \sinh \lambda b \sum_{n=0}^{\infty} \frac{(\lambda r)^{2n}}{(2n)!} \cos 2n\theta, \end{aligned} \quad (23)$$

the resulting expansion is expressed as

$$\left\{ \begin{aligned} \varphi_0 &= p_0 \sum_{n=0}^{\infty} \frac{1}{(2n)!} \left( \int_0^{\infty} \lambda^{2n} (\psi_1(\lambda) \cosh \lambda b \right. \\ &+ \left. \psi_2(\lambda) \sinh \lambda b) d\lambda \right) r^{2n} \cos 2n\theta \\ &+ p_0 \sum_{n=0}^{\infty} \frac{1}{(2n+1)!} \left( \int_0^{\infty} \lambda^{2n+1} (\psi_1(\lambda) \sinh \lambda b \right. \\ &+ \left. \psi_2(\lambda) \cosh \lambda b) d\lambda \right) r^{2n+1} \cos(2n+1)\theta \\ &= p_0 \sum_{n=0}^{\infty} \alpha_n r^n \cos n\theta \\ &= p_0 \sum_{n=0}^{\infty} \alpha_{2n+1} r^{2n+1} \cos(2n+1)\theta \\ &+ p_0 \sum_{n=1}^{\infty} \alpha_{2n} r^{2n} \cos 2n\theta, \end{aligned} \right. \quad (24)$$

$$\left\{ \begin{aligned} \varphi_1 &= p_0 \sum_{n=0}^{\infty} \frac{1}{(2n)!} \left( \int_0^{\infty} \lambda^{2n+1} (\psi_3(\lambda) \cosh \lambda b \right. \\ &+ \left. \psi_4(\lambda) \sinh \lambda b) d\lambda \right) r^{2n} \cos 2n\theta \\ &+ p_0 \sum_{n=0}^{\infty} \frac{1}{(2n+1)!} \left( \int_0^{\infty} \lambda^{2n+2} (\psi_3(\lambda) \sinh \lambda b \right. \\ &+ \left. \psi_4(\lambda) \cosh \lambda b) d\lambda \right) r^{2n+1} \cos(2n+1)\theta \\ &= p_0 \sum_{n=0}^{\infty} \beta_n r^n \cos n\theta \\ &= p_0 \sum_{n=0}^{\infty} \beta_{2n} r^{2n+1} \cos(2n+1)\theta \\ &+ p_0 \sum_{n=1}^{\infty} \beta_{2n-1} r^{2n} \cos 2n\theta, \end{aligned} \right. \quad (25)$$

where

$$\begin{aligned} \alpha_{2n} &= I_n A_0 + \sum_{m=1}^{\infty} [{}^m I_n A_{2m} + {}^m \text{III}_n B_{2m-1}] \\ &+ \sum_{m=0}^{\infty} [{}^m \text{II}_n A_{2m+1} + {}^m \text{IV}_n B_{2m}] + F_{2n} \\ &= \alpha'_{2n} + F_{2n}, \end{aligned} \quad (26)$$

$$\begin{aligned} \left( \alpha'_{2n} &= I_n A_0 + \sum_{m=1}^{\infty} [{}^m I_n A_{2m} + {}^m \text{III}_n B_{2m-1}] \right. \\ &+ \left. \sum_{m=0}^{\infty} [{}^m \text{II}_n A_{2m+1} + {}^m \text{IV}_n B_{2m}] \right) \\ I_n &= \frac{1}{2(2n)!} \int_0^{\infty} \frac{\lambda^{2n-1}}{4\lambda^2 - \sinh^2 2\lambda} \\ &\times \left[ -1 + 4(\kappa - 2\lambda)\lambda + e^{-4\lambda} \right. \\ &+ 2(1+b)\lambda \cosh 2(1-b)\lambda + 2(1-b)\lambda \cosh 2(1+b)\lambda \\ &\left. - \kappa (\sinh 2(1-b)\lambda + \sinh 2(1+b)\lambda) \right] d\lambda, \end{aligned}$$

$$\begin{aligned} {}^m I_n &= \frac{1}{2(2m-1)!(2n)!} \int_0^{\infty} \frac{\lambda^{2m+2n-1}}{4\lambda^2 - \sinh^2 2\lambda} \\ &\times \left[ -1 + 4(\kappa - 2\lambda)\lambda + e^{-4\lambda} \right. \\ &+ 2(1+b)\lambda \cosh 2(1-b)\lambda + 2(1-b)\lambda \cosh 2(1+b)\lambda \\ &\left. - \kappa (\sinh 2(1-b)\lambda + \sinh 2(1+b)\lambda) \right] d\lambda, \\ {}^m \text{II}_n &= -\frac{1}{(2m)!(2n)!} \int_0^{\infty} \frac{\lambda^{2m+2n}}{4\lambda^2 - \sinh^2 2\lambda} \\ &\times \left[ 2b\lambda(2\lambda + \cosh 2b\lambda \sinh 2\lambda) \right. \\ &\left. + (-2\lambda \cosh 2\lambda + \kappa \sinh 2\lambda) \sinh 2b\lambda \right] d\lambda, \end{aligned} \quad (27)$$

$$\begin{aligned} {}^m \text{III}_n &= \frac{1}{4(2m-1)!(2n)!} \int_0^{\infty} \frac{\lambda^{2(m+n-1)}}{4\lambda^2 - \sinh^2 2\lambda} \\ &\times \left[ -16b\kappa\lambda^2 + (\kappa^2 - 1 - 4(1+b)^2\lambda^2) \cosh 2(1-b)\lambda \right. \\ &\left. + (1 - \kappa^2 + 4(-1+b)^2\lambda^2) \cosh 2(1+b)\lambda \right] d\lambda, \end{aligned}$$

$$\begin{aligned} {}^m \text{IV}_n &= \frac{1}{4(2m)!(2n)!} \int_0^{\infty} \frac{\lambda^{2m+2n-1}}{4\lambda^2 - \sinh^2 2\lambda} \\ &\times \left[ 4\lambda(\kappa^2 - 1 - 4(1-b)^2\lambda^2) \right. \\ &- (\kappa^2 - 1 - 4(1+b)^2\lambda^2) \sinh 2(1-b)\lambda \\ &\left. + (1 - \kappa^2 + 4(1-b)^2\lambda^2) \sinh 2(1+b)\lambda \right] d\lambda, \end{aligned}$$

$$\begin{aligned} \alpha_{2n+1} &= I'_n A_0 + \sum_{m=1}^{\infty} [{}^m I'_n A_{2m} + {}^m \text{III}'_n B_{2m-1}] \\ &+ \sum_{m=0}^{\infty} [{}^m \text{II}'_n A_{2m+1} + {}^m \text{IV}'_n B_{2m}] + F_{2n+1} \\ &= \alpha'_{2n+1} + F_{2n+1}, \\ \left( \alpha'_{2n+1} &= I'_n A_0 + \sum_{m=1}^{\infty} [{}^m I'_n A_{2m} + {}^m \text{III}'_n B_{2m-1}] \right. \end{aligned}$$

$$\begin{aligned}
& + \sum_{m=0}^{\infty} [{}^m\Pi'_n A_{2m+1} + {}^mIV'_n B_{2m}] \quad (28) \\
I'_n &= \frac{-1}{2(2n+1)!} \int_0^{\infty} \frac{\lambda^{2n}}{4\lambda^2 - \sinh^2 2\lambda} \\
& \times \left[ 2\kappa \sinh 2\lambda \sinh 2b\lambda \right. \\
& + 2\lambda(-4b\lambda + (-1+b)\sinh 2(1+b)\lambda \\
& \left. + (1+b)\sinh 2(1-b)\lambda) \right] d\lambda, \\
{}^mI'_n &= \frac{1}{(2m-1)!(2n+1)!} \int_0^{\infty} \frac{\lambda^{2(m+n)}}{4\lambda^2 - \sinh^2 2\lambda} \\
& \times \left[ 4b\lambda^2 - 2b\lambda \sinh 2\lambda \cosh 2b\lambda \right. \\
& \left. + (2\lambda \cosh 2\lambda - \kappa \sinh 2\lambda) \sinh 2b\lambda \right] d\lambda, \\
{}^m\Pi'_n &= \frac{1}{2(2m)!(2n+1)!} \int_0^{\infty} \frac{\lambda^{2m+2n+1}}{4\lambda^2 - \sinh^2 2\lambda} \\
& \times \left[ -4\kappa\lambda + 2(1+b)\lambda \cosh 2(1-b)\lambda \right. \\
& + 2(1-b)\lambda \cosh 2(1+b)\lambda \\
& + 1 - e^{-4\lambda} + 8\lambda^2 \\
& \left. - \kappa(\sinh 2(1+b)\lambda + \sinh 2(1-b)\lambda) \right] d\lambda, \quad (29) \\
{}^m\Pi\prime\prime_n &= -\frac{1}{4(2m-1)!(2n+1)!} \int_0^{\infty} \frac{\lambda^{2m+2n-1}}{4\lambda^2 - \sinh^2 2\lambda} \\
& \times \left[ 4\lambda(\kappa^2 - 1 - 4(1-b^2)\lambda^2) \right. \\
& - (1 - \kappa^2 + 4(1+b)^2\lambda^2) \sinh 2(1-b)\lambda \\
& \left. + (\kappa^2 - 1 - 4(1-b)^2\lambda^2) \sinh 2(1+b)\lambda \right] d\lambda, \\
{}^mIV'_n &= \frac{1}{2(2m)!(2n+1)!} \int_0^{\infty} \frac{\lambda^{2(m+n)}}{4\lambda^2 - \sinh^2 2\lambda} \\
& \times \left[ 8b\lambda^2(\kappa - \cosh 2\lambda \cosh 2b\lambda) \right. \\
& \left. + (1 - \kappa^2 + 4(1+b^2)\lambda^2) \sinh 2\lambda \sinh 2b\lambda \right] d\lambda, \\
\beta_{2n-1} &= V_n A_0 + \sum_{m=1}^{\infty} [{}^mV_n A_{2m} + {}^mVII_n B_{2m-1}] \\
& + \sum_{m=0}^{\infty} [{}^mVI_n A_{2m+1} + {}^mVIII_n B_{2m}] + G_{2n-1} \\
& = \beta'_{2n-1} + G_{2n-1}, \\
\left( \beta'_{2n-1} &= V_n A_0 + \sum_{m=1}^{\infty} [{}^mV_n A_{2m} + {}^mVII_n B_{2m-1}] \right. \\
& \left. + \sum_{m=0}^{\infty} [{}^mVI_n A_{2m+1} + {}^mVIII_n B_{2m}] \right) \quad (30) \\
V_n &= -\frac{2}{(2n)!} \int_0^{\infty} \frac{\lambda^{2n} \sinh 2\lambda \sinh 2b\lambda}{4\lambda^2 - \sinh^2 2\lambda} d\lambda, \\
{}^mV_n &= -\frac{2}{(2m-1)!(2n)!} \\
& \times \int_0^{\infty} \frac{\lambda^{2(m+n)} \sinh 2\lambda \sinh 2b\lambda}{4\lambda^2 - \sinh^2 2\lambda} d\lambda,
\end{aligned}$$

$$\begin{aligned}
{}^mVI_n &= -\frac{1}{(2m)!(2n)!} \\
& \times \int_0^{\infty} \frac{\lambda^{2m+2n+1} (4\lambda + \sinh 2(1+b)\lambda + \sinh 2(1-b)\lambda)}{4\lambda^2 - \sinh^2 2\lambda} d\lambda, \\
{}^mVII_n &= \frac{1}{2(2m-1)!(2n)!} \int_0^{\infty} \frac{\lambda^{2m+2n-1}}{4\lambda^2 - \sinh^2 2\lambda} \\
& \times \left[ -1 - 4\lambda(\kappa + 2\lambda) + e^{-4\lambda} - 2(1+b)\lambda \cosh 2(1-b)\lambda \right. \\
& - 2(1-b)\lambda \cosh 2(1+b)\lambda \\
& \left. - \kappa(\sinh 2(1-b)\lambda + \sinh 2(1+b)\lambda) \right] d\lambda, \quad (31) \\
{}^mVIII_n &= \frac{1}{(2m)!(2n)!} \int_0^{\infty} \frac{\lambda^{2(m+n)}}{4\lambda^2 - \sinh^2 2\lambda} \\
& \times \left[ 2b\lambda(2\lambda + \cosh 2b\lambda \sinh 2\lambda) \right. \\
& \left. - (2\lambda \cosh 2\lambda + \kappa \sinh 2\lambda) \sinh 2b\lambda \right] d\lambda, \\
\beta_{2n} &= V'_n A_0 + \sum_{m=1}^{\infty} [{}^mV'_n A_{2m} + {}^mVII'_n B_{2m-1}] \\
& + \sum_{m=0}^{\infty} [{}^mVI'_n A_{2m+1} + {}^mVIII'_n B_{2m}] + G_{2n} \\
& = \beta'_{2n} + G_{2n}, \\
\left( \beta'_{2n} &= V'_n A_0 + \sum_{m=1}^{\infty} [{}^mV'_n A_{2m} + {}^mVII'_n B_{2m-1}] \right. \\
& \left. + \sum_{m=0}^{\infty} [{}^mVI'_n A_{2m+1} + {}^mVIII'_n B_{2m}] \right) \quad (32) \\
V'_n &= \frac{2}{(2n+1)!} \int_0^{\infty} \frac{\lambda^{2n+1} (2\lambda - \sinh 2\lambda \cosh 2b\lambda)}{4\lambda^2 - \sinh^2 2\lambda} d\lambda, \\
{}^mV'_n &= \frac{2}{(2m-1)!(2n+1)!} \\
& \times \int_0^{\infty} \frac{\lambda^{2m+2n+1} (2\lambda - \sinh 2\lambda \cosh 2b\lambda)}{4\lambda^2 - \sinh^2 2\lambda} d\lambda, \\
{}^mVI'_n &= -\frac{2}{(2m)!(2n+1)!} \\
& \times \int_0^{\infty} \frac{\lambda^{2(m+n+1)} \sinh 2\lambda \sinh 2b\lambda}{4\lambda^2 - \sinh^2 2\lambda} d\lambda, \quad (33) \\
{}^mVII'_n &= -\frac{1}{(2m-1)!(2n+1)!} \int_0^{\infty} \frac{\lambda^{2(m+n)}}{4\lambda^2 - \sinh^2 2\lambda} \\
& \times \left[ 2b\lambda(2\lambda - \sinh 2\lambda \cosh 2b\lambda) \right. \\
& \left. + (2\lambda \cosh 2\lambda + \kappa \sinh 2\lambda) \sinh 2b\lambda \right] d\lambda, \\
{}^mVIII'_n &= \frac{1}{2(2m)!(2n+1)!} \int_0^{\infty} \frac{\lambda^{2m+2n+1}}{4\lambda^2 - \sinh^2 2\lambda} \\
& \times \left[ 1 + 4\lambda(\kappa + 2\lambda) - e^{-4\lambda} - 2(1+b)\lambda \cosh 2(1-b)\lambda \right. \\
& - 2(1-b)\lambda \cosh 2(1+b)\lambda \\
& \left. - \kappa(\sinh 2(1-b)\lambda + \sinh 2(1+b)\lambda) \right] d\lambda.
\end{aligned}$$

If we use the following integral functions, which are similar to Howland's integrals<sup>(3)</sup>,

$$\begin{aligned}
 I_k &= \frac{2^k}{k!} \int_0^\infty \left( \frac{1}{\sinh 2\lambda - 2\lambda} + \frac{1}{\sinh 2\lambda + 2\lambda} \right) \lambda^k d\lambda \\
 I_k^* &= \frac{2^k}{k!} \int_0^\infty \left( \frac{1}{\sinh 2\lambda - 2\lambda} - \frac{1}{\sinh 2\lambda + 2\lambda} \right) \lambda^k d\lambda \\
 J_k &= \frac{2^k}{k!} \int_0^\infty \left( \frac{1}{\sinh 2\lambda - 2\lambda} + \frac{1}{\sinh 2\lambda + 2\lambda} \right) \\
 &\quad \times \sinh 2b\lambda \cdot \lambda^k d\lambda \\
 J_k^* &= \frac{2^k}{k!} \int_0^\infty \left( \frac{1}{\sinh 2\lambda - 2\lambda} - \frac{1}{\sinh 2\lambda + 2\lambda} \right) \\
 &\quad \times \sinh 2b\lambda \cdot \lambda^k d\lambda \\
 K_k &= \frac{2^k}{k!} \int_0^\infty \left( \frac{1}{\sinh 2\lambda - 2\lambda} + \frac{1}{\sinh 2\lambda + 2\lambda} \right) \\
 &\quad \times \cosh 2b\lambda \cdot \lambda^k d\lambda \\
 K_k^* &= \frac{2^k}{k!} \int_0^\infty \left( \frac{1}{\sinh 2\lambda - 2\lambda} - \frac{1}{\sinh 2\lambda + 2\lambda} \right) \\
 &\quad \times \cosh 2b\lambda \cdot \lambda^k d\lambda \\
 L_k &= \frac{2^k}{k!} \int_0^\infty \left( \frac{1}{\sinh 2\lambda - 2\lambda} + \frac{1}{\sinh 2\lambda + 2\lambda} \right) e^{-2\lambda} \cdot \lambda^k d\lambda \\
 L_k^* &= \frac{2^k}{k!} \int_0^\infty \left( \frac{1}{\sinh 2\lambda - 2\lambda} - \frac{1}{\sinh 2\lambda + 2\lambda} \right) e^{-2\lambda} \cdot \lambda^k d\lambda \\
 M_k &= \frac{2^k}{k!} \int_0^\infty \left( \frac{1}{\sinh 2\lambda - 2\lambda} + \frac{1}{\sinh 2\lambda + 2\lambda} \right) \\
 &\quad \times e^{-2\lambda} \sinh 2b\lambda \cdot \lambda^k d\lambda \\
 M_k^* &= \frac{2^k}{k!} \int_0^\infty \left( \frac{1}{\sinh 2\lambda - 2\lambda} - \frac{1}{\sinh 2\lambda + 2\lambda} \right) \\
 &\quad \times e^{-2\lambda} \sinh 2b\lambda \cdot \lambda^k d\lambda \\
 N_k &= \frac{2^k}{k!} \int_0^\infty \left( \frac{1}{\sinh 2\lambda - 2\lambda} + \frac{1}{\sinh 2\lambda + 2\lambda} \right) \\
 &\quad \times e^{-2\lambda} \cosh 2b\lambda \cdot \lambda^k d\lambda \\
 N_k^* &= \frac{2^k}{k!} \int_0^\infty \left( \frac{1}{\sinh 2\lambda - 2\lambda} - \frac{1}{\sinh 2\lambda + 2\lambda} \right) \\
 &\quad \times e^{-2\lambda} \cosh 2b\lambda \cdot \lambda^k d\lambda \\
 O_k &= \frac{2^k}{k!} \int_0^\infty \left( \frac{1}{\sinh 2\lambda - 2\lambda} + \frac{1}{\sinh 2\lambda + 2\lambda} \right) \\
 &\quad \times \frac{\cosh 2\lambda}{\sinh 2\lambda} \sinh 2b\lambda \cdot \lambda^k d\lambda \\
 P_k &= \frac{2^k}{k!} \int_0^\infty \left( \frac{1}{\sinh 2\lambda - 2\lambda} + \frac{1}{\sinh 2\lambda + 2\lambda} \right) \\
 &\quad \times \frac{\cosh 2\lambda}{\sinh 2\lambda} \cosh 2b\lambda \cdot \lambda^k d\lambda,
 \end{aligned}$$

we can transform the integrals Eqs. (27)–(33) into

$$\begin{aligned}
 I_n &= \frac{1}{2^{2n+1}(2n)(2n-1)} \\
 &\quad \times \left[ -3I_{2n-2}^* + 2(2n-1) \left( -\kappa I_{2n-1}^* + L_{2n-1} + \kappa K_{2n-1} \right) \right. \\
 &\quad \left. + 2(2n)(2n-1) \left( I_{2n}^* + 2P_{2n} + 2bJ_{2n} \right) \right], \\
 {}^m I_n &= \frac{(2m+2n-2)!}{2^{2m+2n+1}(2m-1)!(2n)!}
 \end{aligned}$$

$$\begin{aligned}
 &\quad \times \left[ -3I_{2m+2n-2} \right. \\
 &\quad \left. + 2(2m+2n-1) \left( -\kappa I_{2m+2n-1}^* + L_{2m+2n-1} + \kappa K_{2m+2n-1} \right) \right. \\
 &\quad \left. + 2(2m+2n)(2m+2n-1) \left( I_{2m+2n}^* + P_{2m+2n} + bJ_{2m+2n} \right) \right], \\
 {}^m II_n &= \frac{(2m+2n)!}{2^{2m+2n+1}(2m)!(2n)!} \\
 &\quad \times \left[ \kappa J_{2m+2n} \right. \\
 &\quad \left. + (2m+2n+1) \left( bI_{2m+2n+1}^* + bK_{2m+2n+1} + O_{2m+2n+1} \right) \right], \\
 {}^m III_n &= \frac{(2m+2n-2)!}{2^{2m+2n}(2m-1)!(2n)!} \\
 &\quad \times \left[ (\kappa^2 - 1)J_{2m+2n-2} + 2b\kappa(2m+2n-1)I_{2m+2n-1}^* \right. \\
 &\quad \left. - (2m+2n)(2m+2n-1) \left( 2bP_{2m+2n} + (1+b^2)J_{2m+2n} \right) \right], \\
 {}^m IV_n &= \frac{(2m+2n-1)!}{2^{2m+2n+1}(2m)!(2n)!} \left[ (\kappa^2 - 1) \left( K_{2m+2n-1} - I_{2m+2n-1}^* \right) \right. \\
 &\quad \left. + (2m+2n+1)(2m+2n) \right. \\
 &\quad \left. \times \left( (1-b^2)I_{2m+2n+1}^* - (1+b^2)K_{2m+2n+1} - 2bO_{2m+2n+1} \right) \right], \tag{34}
 \end{aligned}$$

$$\begin{aligned}
 I_n' &= \frac{1}{2^{2n+1}} \left[ \frac{\kappa}{2n+1} J_{2n} + b(-I_{2n+1}^* + K_{2n+1}) + O_{2n+1} \right], \\
 {}^m I_n' &= \frac{(2m+2n+1)!}{2^{2m+2n+1}(2m-1)!(2n+1)!} \\
 &\quad \times \left[ b \left( -I_{2m+2n+1}^* + K_{2m+2n+1} \right) \right. \\
 &\quad \left. + O_{2m+2n+1} + \frac{\kappa}{2m+2n+1} J_{2m+2n} \right], \\
 {}^m II_n' &= \frac{(2m+2n)!}{2^{2m+2n+2}(2m)!(2n+1)!} \\
 &\quad \times \left[ \frac{3}{2} I_{2m+2n}^* + (2m+2n+1) \right. \\
 &\quad \times \left( \kappa I_{2m+2n+1}^* - L_{2m+2n+1} + \kappa K_{2m+2n+1} \right) \\
 &\quad \left. + (2m+2n+2)(2m+2n+1) \right. \\
 &\quad \left. \times \left( P_{2m+2n+2} + bJ_{2m+2n+2} - I_{2m+2n+2}^* \right) \right], \\
 {}^m III_n' &= \frac{(2m+2n-1)!}{2^{2m+2n+1}(2m-1)!(2n+1)!} \\
 &\quad \times \left[ (\kappa^2 - 1) \left( I_{2m+2n-1}^* + K_{2m+2n-1} \right) \right.
 \end{aligned}$$

$$\begin{aligned}
 & - (2m + 2n + 1)(2m + 2n) \\
 & \times \left[ (b^2 + 1)(K_{2m+2n+1} + O_{2m+2n+1}) + (1 - b^2)I_{2m+2n+1}^* \right], \\
 {}^mV_n' &= - \frac{(2m + 2n)!}{2^{2m+2n+2}(2m)!(2n + 1)!} \\
 & \times \left[ 2bk(2m + 2n + 1)I_{2m+2n+1}^* + (1 - \kappa^2)J_{2m+2n} \right. \\
 & + (2m + 2n + 2)(2m + 2n + 1) \\
 & \left. \times \left( 2bP_{2m+2n+2} + (1 + b^2)J_{2m+2n+2} \right) \right], \quad (35)
 \end{aligned}$$

$$\begin{aligned}
 V_n &= \frac{1}{2^{2n}} J_{2n}, \\
 {}^mV_n &= \frac{(2m + 2n)!}{2^{2m+2n}(2m - 1)!(2n)!} J_{2m+2n}, \\
 {}^mV_n &= \frac{(2m + 2n + 1)!}{2^{2m+2n+1}(2m)!(2n)!} \left( I_{2m+2n+1}^* + K_{2m+2n+1} \right), \\
 {}^mV_n &= \frac{(2m + 2n - 2)!}{2^{2m+2n}(2m - 1)!(2n)!} \\
 & \times \left[ - \frac{3}{2} I_{2m+2n-2}^* + (2m + 2n - 1) \right. \\
 & \left. \times \left( \kappa(I_{2m+2n-1}^* + K_{2m+2n-1}) + L_{2m+2n-1} \right) \right. \\
 & \left. + (2m + 2n)(2m + 2n - 1) \left( I_{2m+2n}^* - P_{2m+2n} - bJ_{2m+2n} \right) \right], \quad (36)
 \end{aligned}$$

$$\begin{aligned}
 {}^mV_n &= - \frac{(2m + 2n + 1)!}{2^{2m+2n+1}(2m)!(2n)!} \\
 & \times \left[ b(I_{2m+2n+1}^* + K_{2m+2n+1}) + O_{2m+2n+1} \right. \\
 & \left. - \frac{\kappa}{2m + 2n + 1} J_{2m+2n} \right], \\
 V_n' &= \frac{1}{2^{2n+1}} \left[ -I_{2n+1}^* + K_{2n+1} \right], \\
 {}^mV_n' &= \frac{(2m + 2n + 1)!}{2^{2m+2n+1}(2m - 1)!(2n + 1)!} \left[ -I_{2m+2n+1}^* + K_{2m+2n+1} \right], \\
 {}^mV_n' &= \frac{(2m + 2n + 2)!}{2^{2m+2n+2}(2m)!(2n + 1)!} J_{2m+2n+2}, \\
 {}^mV_n' &= - \frac{(2m + 2n + 1)!}{2^{2m+2n+1}(2m - 1)!(2n + 1)!} \\
 & \times \left[ b \left( -I_{2m+2n+1}^* + K_{2m+2n+1} \right) + O_{2m+2n+1} \right. \\
 & \left. - \frac{\kappa}{2m + 2n + 1} J_{2m+2n} \right], \quad (37) \\
 {}^mV_n' &= \frac{(2m + 2n)!}{2^{2m+2n+2}(2m)!(2n + 1)!}
 \end{aligned}$$

$$\begin{aligned}
 & \times \left[ \frac{3}{2} I_{2m+2n}^* + (2m + 2n + 1) \right. \\
 & \left. \times \left( -\kappa I_{2m+2n+1}^* - L_{2m+2n+1} + \kappa K_{2m+2n+1} \right) \right. \\
 & - (2m + 2n + 2)(2m + 2n + 1) \\
 & \left. \times \left( I_{2m+2n+2}^* + P_{2m+2n+2} + bJ_{2m+2n+2} \right) \right].
 \end{aligned}$$

$F_n$  and  $G_n$  in Eqs. (26), (28), (30) and (32), which originate from the side pressure  $p_0$ , are expressed as

$$\begin{aligned}
 F_{2n} &= \frac{2}{\pi(2n)!} \int_0^\infty \frac{\lambda^{2n-3} \sin \lambda c}{2\lambda + \sinh 2\lambda} \left[ -2\lambda \cosh \lambda \cosh b\lambda \right. \\
 & \left. + \sinh \lambda \left( (\kappa - 1) \cosh b\lambda + 2b\lambda \sinh b\lambda \right) \right] d\lambda, \\
 F_{2n+1} &= \frac{2}{\pi(2n+1)!} \int_0^\infty \frac{\lambda^{2n-2} \sin \lambda c}{2\lambda + \sinh 2\lambda} \left[ 2b\lambda \sinh \lambda \cosh b\lambda \right. \\
 & \left. - \left( 2\lambda \cosh \lambda - (\kappa - 1) \sinh \lambda \right) \sinh b\lambda \right] d\lambda, \quad (38)
 \end{aligned}$$

$$\begin{aligned}
 G_{2n-1} &= \frac{4}{\pi(2n)!} \int_0^\infty \frac{\lambda^{2n-2} \sin \lambda c}{2\lambda + \sinh 2\lambda} \sinh \lambda \sinh b\lambda d\lambda, \\
 G_{2n} &= \frac{4}{\pi(2n+1)!} \int_0^\infty \frac{\lambda^{2n-1} \sin \lambda c}{2\lambda + \sinh 2\lambda} \sinh \lambda \cosh b\lambda d\lambda.
 \end{aligned}$$

Deriving the stresses from the potential functions given by [II] and [IV] and satisfying the boundary conditions expressed by Eq. (6), we obtain two sets of equations for determining the unknown constants  $A_n$  and  $B_n$ .

(i) Normal stress around the hole must be free ( $(\sigma_r/p_0)_{r=a} = 0$ );

$$\begin{aligned}
 & \frac{A_0}{a^2} + \frac{\kappa + 1}{2a^2} B_0 - \beta'_0 + \left( 2 \frac{A_1}{a^3} + \frac{\kappa + 2}{a^3} B_1 - a\beta'_1 \right) \cos \theta \\
 & + \sum_{n=2}^\infty \left[ s_{A1} A_n + s_{B1} B_{n-2} + s_{B2} B_n \right. \\
 & \left. + s_{\alpha 1} \alpha'_n + s_{\beta 1} \beta'_{n-2} + s_{\beta 2} \beta'_n \right] \cos n\theta \\
 & = G_0 + aG_1 \cos \theta
 \end{aligned} \quad (39)$$

(ii) Shear stress around the hole must be free ( $(\tau_{r\theta}/p_0)_{r=a} = 0$ );

$$\begin{aligned}
 & \left( \frac{2}{a^3} A_1 + \frac{\kappa + 2}{a^3} B_1 - a\beta'_1 \right) \sin \theta \\
 & + \sum_{n=2}^\infty \left[ t_{A1} A_n + t_{B1} B_{n-2} + t_{B2} B_n \right. \\
 & \left. + t_{\alpha 1} \alpha'_n + t_{\beta 1} \beta'_{n-2} + t_{\beta 2} \beta'_n \right] \sin n\theta \\
 & = aG_1 \sin \theta + \sum_{n=2}^\infty \left[ t_{F1} F_n + t_{G1} G_{n-2} + t_{G2} G_n \right] \sin n\theta
 \end{aligned} \quad (40)$$

where

$$s_{A1} = \frac{n(n+1)}{a^{n+2}},$$



$$\begin{aligned}
 s_{B1} &= \frac{(n-1)(n+2)}{2a^n}, & s_{B2} &= \frac{(n+1)(n+\kappa+1)}{2a^{n+2}}, \\
 s_{\alpha 1} &= n(n-1)a^{n-2}, \\
 s_{\beta 1} &= \frac{(n-1)(n-\kappa-1)}{2}a^{n-2}, & s_{\beta 2} &= \frac{(n+1)(n-2)}{2}a^n
 \end{aligned} \tag{41}$$

$$\begin{aligned}
 t_{A1} &= \frac{n(n+1)}{a^{n+2}}, \\
 t_{B1} &= \frac{n(n-1)}{2a^n}, & t_{B2} &= \frac{(n+1)(n+\kappa+1)}{2a^{n+2}}, \\
 t_{\alpha 1} &= -n(n-1)a^{n-2}, \\
 t_{\beta 1} &= -\frac{(n-1)(n-\kappa-1)}{2}a^{n-2}, & t_{\beta 2} &= -\frac{n(n+1)}{2}a^n
 \end{aligned} \tag{42}$$

$$\begin{aligned}
 s_{F1} &= -n(n-1)a^{n-2}, \\
 s_{G1} &= -\frac{(n-1)(n-\kappa-1)}{2}a^{n-2}, \\
 s_{G2} &= -\frac{(n+1)(n-2)}{2}a^n, \\
 t_{F1} &= n(n-1)a^{n-2}, \\
 t_{G1} &= \frac{(n-1)(n-\kappa-1)}{2}a^{n-2}, & t_{G2} &= \frac{n(n+1)}{2}a^n
 \end{aligned} \tag{43}$$

By equating the coefficients of  $\cos n\theta$  and  $\sin n\theta$  on the left- and right-hand sides of Eqs. (39) and (40), an infinite set of algebraic equations for the unknown constants  $A_n$  and  $B_n$  is obtained. Each set of unknowns is associated with an integer  $n$ , which varies from zero or one to infinity. We evaluate these unknown constants by truncating the infinite number to  $n = N$ .  $N$  is set to 20 to satisfy the boundary conditions on the rim to at least three significant figures.

All displacements and stresses are obtained by the linear combination of potentials [I] and [II].

### 3. Numerical Results

In the numerical examples, we assume plane stress. Numerical calculations are carried out for various hole radii  $a$ , eccentricity  $b$  and pressure length  $c$ . Poisson's ratios  $\nu$  is considered as 0.3. The stress components at an arbitrary point of the strip are calculated using

$$\begin{aligned}
 \frac{\sigma_r}{p_0} &= \frac{A_0}{r^2} + \frac{\kappa+1}{2} \frac{B_0}{r^2} - \beta_0 \\
 &+ \sum_{n=1}^{\infty} \left\{ \frac{2n(2n+1)}{r^{2n+2}} A_n + \left( \frac{\kappa+1}{2} + n \right) \frac{2n+1}{r^{2n+2}} B_n \right. \\
 &+ (n+1) \frac{2n-1}{r^{2n}} B_{n-1} + (2n-1) 2n \alpha_n r^{2n-2} \\
 &+ (n-1)(2n+1) \beta_n r^{2n} \\
 &\left. + \left( n - \frac{\kappa+1}{2} \right) (2n-1) \beta_{n-1} r^{2n-2} \right\} \cos 2n\theta, \tag{44} \\
 \frac{\tau_{r\theta}}{p_0} &= \sum_{n=1}^{\infty} \left\{ \frac{2n(2n+1)}{r^{2n+2}} A_n + \left( n + \frac{\kappa+1}{2} \right) \frac{2n+1}{r^{2n+2}} B_n \right.
 \end{aligned}$$

$$\begin{aligned}
 &+ \frac{n(2n-1)}{r^{2n}} B_{n-1} \\
 &- 2n(2n-1) \alpha_n r^{2n-2} - n(2n+1) \beta_n r^{2n} \\
 &\left. - \left( n - \frac{\kappa+1}{2} \right) (2n-1) \beta_{n-1} r^{2n-2} \right\} \sin 2n\theta, \tag{45}
 \end{aligned}$$

$$\begin{aligned}
 \frac{\sigma_\theta}{p_0} &= -\frac{A_0}{r^2} - \frac{\kappa+1}{2} \frac{B_0}{r^2} - \beta_0 \\
 &- \sum_{n=1}^{\infty} \left\{ \frac{2n(2n+1)}{r^{2n+2}} A_n + \left( \frac{\kappa+1}{2} + n \right) \frac{2n+1}{r^{2n+2}} B_n \right. \\
 &+ \frac{(n-1)(2n-1)}{r^{2n}} B_{n-1} + 2n(2n-1) \alpha_n r^{2n-2} \\
 &+ (n+1)(2n+1) \beta_n r^{2n} \\
 &\left. - \left( \frac{\kappa+1}{2} - n \right) (2n-1) \beta_{n-1} r^{2n-2} \right\} \cos 2n\theta. \tag{46}
 \end{aligned}$$

To confirm the validity of the present method, we compare our numerical results with those of FEM. In the FEM analysis, a four-node isoparametric element is employed, and the strip is divided into 1348 elements. Figure 2 shows the mesh pattern of FEM and stress contour  $\sigma_x$  obtained by FEM. Figure 3 shows the present and FEM results of  $\sigma_\theta$  around the hole for  $c = 1.0$ ,  $b = 0.4$  and  $a = 0.4$ . In the figure, we can see that the present results agree well with the FEM results.

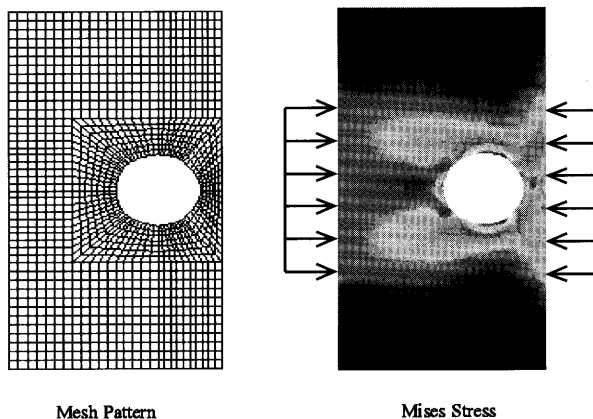

Fig. 2 Mesh pattern and Mises stress contour obtained by FEM

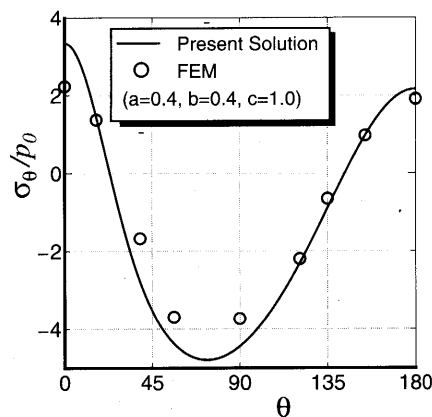

Fig. 3 Comparison of present and FEM results for hoop stress  $\sigma_\theta$  ( $a = 0.4$ ,  $b = 0.4$ ,  $c = 1.0$ )

First, consider the effects of the eccentricity  $b$  on the hoop stress  $\sigma_\theta$  around the circular hole. Figures 4–6 show the variations in  $\sigma_\theta$  around the hole with  $\theta$  (see Fig. 1) for  $c = 0.5$  and  $a = 0.2, 0.4$  and  $0.6$ . As expected, the eccen-

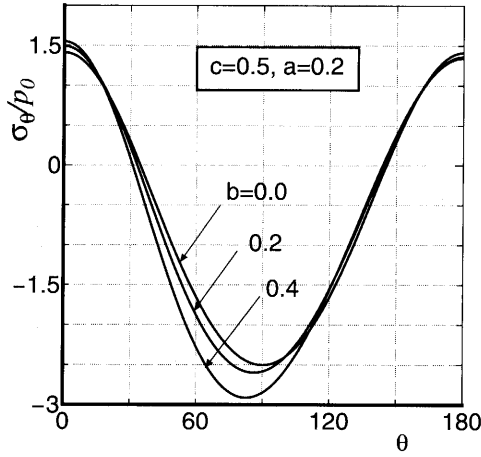

Fig. 4 Variation in hoop stress  $\sigma_\theta$  around hole with  $\theta$  ( $c=0.5$ ,  $a=0.2$ )

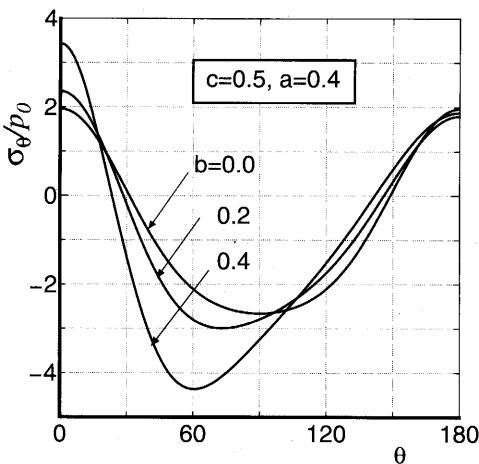

Fig. 5 Variation in hoop stress  $\sigma_\theta$  around hole with  $\theta$  ( $c=0.5$ ,  $a=0.4$ )

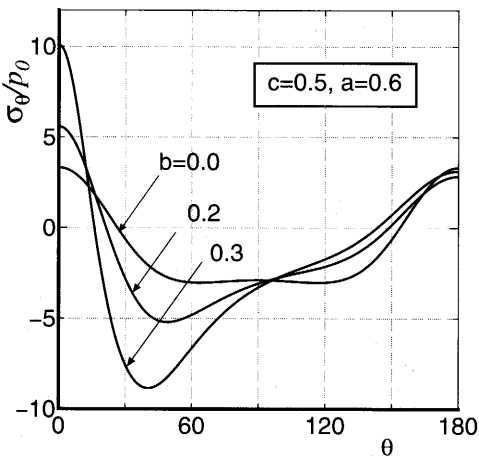

Fig. 6 Variation in hoop stress  $\sigma_\theta$  around hole with  $\theta$  ( $c=0.5$ ,  $a=0.6$ )

tricity  $b$  has a small effect on the stress  $\sigma_\theta$  around the hole when the radius  $a$  is small and a large effect when  $a$  is large. When  $a$  is small, the compressive stress  $\sigma_\theta$  is maximum at the neighborhood of the pole of the hole, indicating that  $\sigma_\theta$  is not markedly affected by  $b$ . When  $b$  is large,  $\sigma_\theta$  is maximum at the deviated position towards point C (see Fig. 1) from point A.

Figure 7 shows the variations in  $\sigma_\theta$  around the hole with  $\theta$  for  $a = 0.4$ . Tensile stress at point A is weakly affected by the length of the load  $c$ ; however, it is strongly affected by the eccentricity  $b$ . The maximum compressive stress along the hole is affected by both  $b$  and  $c$ .

Figures 8 and 9 show the variations in  $\sigma_y$  with  $x$  for  $c = 0.5$ ,  $a = 0.2$  and  $c = 0.5$ ,  $a = 0.4$  on the  $x$ -axis. The compressive stress on the right-hand side of the strip increases with  $b$ .

From the practical viewpoint of mechanical design, it may be more useful to evaluate the stresses at points A, B and C than to evaluate the above-mentioned stress components. Thus, we define the stresses at points A, B and C as  $(\sigma_y)_A = (\sigma_y)_{x=a,y=0}$ ,  $(\sigma_y)_B = (\sigma_y)_{x=1,y=0}$  and

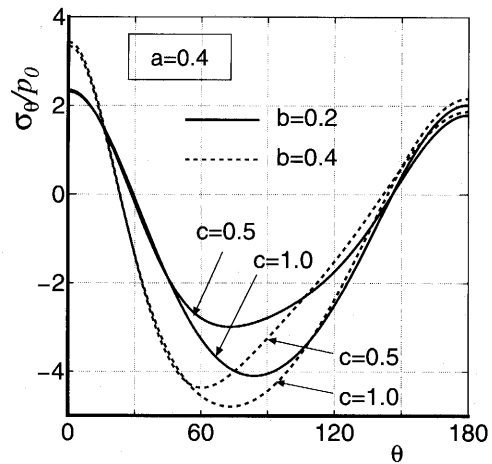

Fig. 7 Variation in hoop stress  $\sigma_\theta$  around hole with  $\theta$  ( $b=0.2, 0.4$ ,  $a=0.4$ )

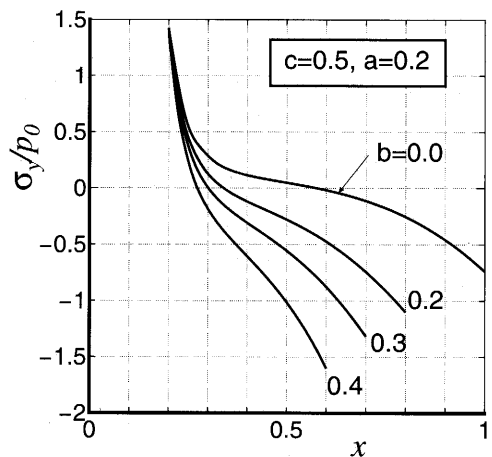

Fig. 8  $\sigma_y$  on  $x$ -axis ( $c=0.5$ ,  $a=0.2$ )

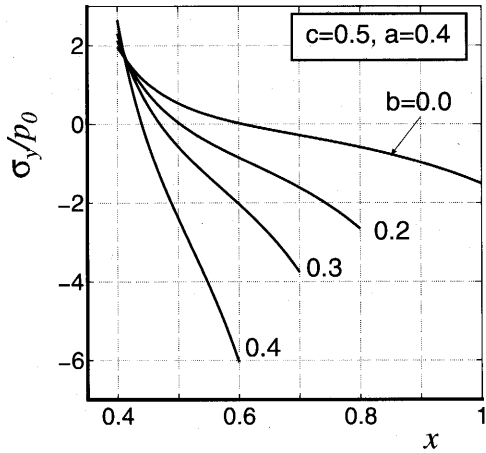

Fig. 9  $\sigma_y$  on  $x$ -axis ( $c=0.5, a=0.4$ )

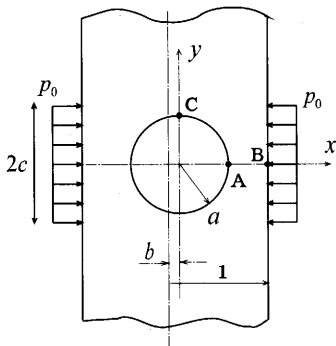

Fig. 10 Definitions of stresses  $\sigma_A, \sigma_B$  and  $\sigma_C$  at points A, B and C

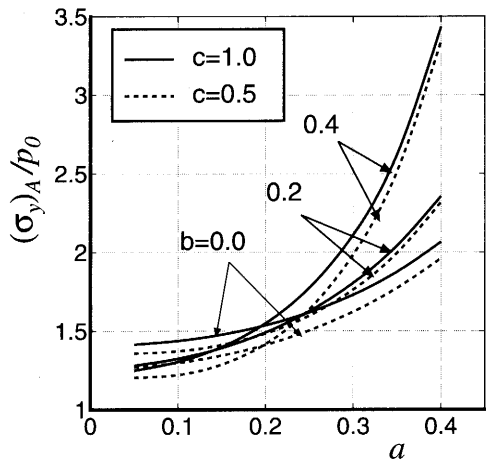

Fig. 11 Variation in stress  $(\sigma_y)_A$  with hole radius  $a$  ( $c=0.5, 1.0$ )

$(\sigma_x)_C$  ( $= (\sigma_x)_{x=0, y=a}$ ), respectively as shown in Fig. 10.

Figures 11–13 show the variations in  $(\sigma_y)_A$ ,  $(\sigma_y)_B$  and  $(\sigma_x)_C$  with the hole radius  $a$  for  $c=0.5$  and  $1.0$ . The stresses  $(\sigma_y)_A$  and  $(\sigma_y)_B$  are caused by the bending of the ligament of the strip and fairly affected by the hole size  $a$ . On the other hand, the compressive stress  $(\sigma_x)_A$  is insensitive to the hole size  $a$ .

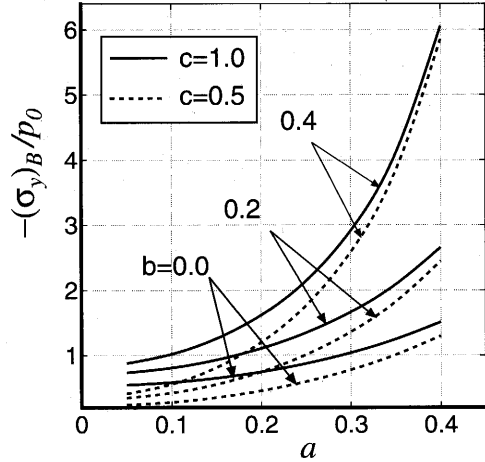

Fig. 12 Variation in stress  $(\sigma_y)_B$  with hole radius  $a$  ( $c=0.5, 1.0$ )

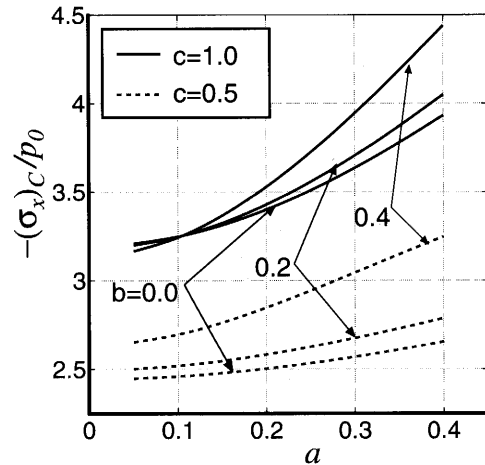

Fig. 13 Variation in stress  $(\sigma_x)_C$  with hole radius  $a$  ( $c=0.5, 1.0$ )

#### 4. Conclusion

In this study, we developed a method of solving unsymmetric problem of an infinite strip having an eccentric circular hole when the strip was subjected to side pressures. Following an analysis, we carried out some numerical calculations for an eccentric hole, showing the stress distributions around the hole and the effects of eccentricity on stress concentration.

On the basis of the preceding presentation, the following conclusions are drawn:

(1) The tensile stress around the circular hole is maximum at position A (see Fig. 1) and the compressive stress is maximum at the deviated position towards point C from point A when  $b$  is large.

(2) The effect of the eccentricity  $b$  is stronger when the hole radius  $a$  is large.

The authors wish to express their gratitude to Prof. Emeritus M. Ueno of Ibaraki National College Technology for encouragement in the preparation of this paper.

## References

- (1) Savin, G.N., Stress Concentration Around Holes, (1961), Pergamon Press.
- (2) Nakahara, I., Shibuya, H., Tsuchida, E., Tsuji, T. and Inoue, Y., Handbook of Elasticity, (2001), p.284, Asakura Book Co.
- (3) Howland, R.C.J., On the Stresses in the Neighborhood of a Circular Hole in a Strip under Tension, Proc. Roy. Soc. Lond., Ser.A, Vol.229 (1930), pp.49–86.
- (4) Ling, C.B., Stresses in a Perforated Strip, Trans. ASME, J. Appl. Mech., Vol.24 (1957), pp.365–375.
- (5) Itou, S., The Effect of Couple-Stresses on Stress Concentrations around a Circular Hole in a Strip under Tension, Int. J. Eng. Sci., Vol.14, No.9 (1976), pp.861–867.
- (6) Theotokoglou, E.N. and Tsamasphyros, G.J., Stress Concentration for a Circular Hole in a Strip by Singular Integral Equations, Mech. Res. Commun., Vol.13, No.4 (1986), pp.221–229.
- (7) Ishida, M., Tension of a Strip with an Eccentric Hole, Trans. Jpn. Soc. Mech. Eng., (in Japanese), Vol.19, No.87 (1953), pp.100–106.
- (8) Tsuchida, E., Togawa, S., Nakahara, I. and Kodama, M., Uniaxial Tension of a Thick Plate with an Eccentric Cavity, Trans. Jpn. Soc. Mech. Eng., (in Japanese), Vol.41, No.352 (1975), pp.3366–3378.
- (9) Tsuchida, E., Maeda, K., Nakahara, I. and Kodama, M., Bending of a Thick Plate with an Eccentric Cavity, Trans. Jpn. Soc. Mech. Eng., (in Japanese), Vol.43, No.369 (1977), pp.1629–1641.
- (10) Kawakami, T., Nakahara, I., Tsuchida, E. and Matsumoto, H., Tension of an Infinite Cylinder with an Eccentric Cavity, Trans. Jpn. Soc. Mech. Eng., (in Japanese), Vol.45, No.397, A (1979), pp.990–997.
- (11) Kawakami, T. and Nakahara, I., Torsion of an Infinite Cylinder with an Eccentric Cavity, Trans. Jpn. Soc. Mech. Eng., (in Japanese), Vol.47, No.419, A (1981), pp.720–729.
- (12) Lee, M., Jasiuk, I. and Tsuchida, E., The Sliding Circular Inclusion in an Elastic Half-Plane, Trans. ASME, J. Appl. Mech., Vol.59 (1992), pp.57–64.
- (13) Horibe, T. and Takahashi H., Stresses Around a Hole in an Infinite Strip Subjected to Uniformly Distributed Side Pressure, Proc. 1st Int. Conf. on Design Engineering and Science (ICDES-2005), (2005), pp.427–432.